

LS-3 USER & SERVICE MANUAL

Portable Filter Machine



Anodized Aluminum Filter Machine Models:
LS-3-60



USER MANUAL

Portable Filter Machine

Thank you for purchasing a FILTROX portable cooking oil filter. FILTROX is a leading manufacturer of premium quality filter equipment. We are proud of our reputation for quality and our commitment to customer satisfaction.

To get the maximum benefit this equipment can deliver, please read this User Manual and Instruction Sheet that was included with this appliance. Ensure anyone using this equipment is familiar with the information in this Manual and Instruction sheet.

We are here to help support you should you need help. Our technical support center is staffed by experienced technicians eager to help you. Our Customer Service number is (800)473-4526, and we are available 8:00 am (pst) to 4:00 pm (pst).



USER MANUAL

Portable Filter Machine



Table of Contents | User Manual

Introduction	Page 4
Description & construction	Page 5
Product Safety	Page 6
Operating Instructions	Page 7-8
Frying Oil Maintenance Equipment	Page 9
Specifications	Page 10
Dimensions and Detail Drawing	Page 11
Troubleshooting	Page 12
Protection Apparel	Page 13
Equipment Warranty	Page 14
Warranty Registration	Page 15

USER MANUAL

Portable Filter Machine



Introduction

Please read all sections of this manual and retain for future reference. The LS-3 Portable Filter is designed to remove food and other solids from the cooking oil used in your deep fat fryer.

For best results use SuperSorb® Carbon Pads.

The LS-3 Filter rolls easily for use wherever it is needed and can easily be stored out of the way. The low profile allows the unit to roll directly under the drain valve outlet extension pipe on the fryer. This design makes it easier to drain the fryer.

! ATTENTION

This product has been certified as commercial cooking equipment and is intended for professional use only and is to be operated by qualified personnel only. A FILTROX Authorized Service Center (FASC) should perform maintenance and repairs. Installation or repairs by unqualified personnel may void the manufacturer's warranty.

! WARNING

Improper installation, adjustment, alteration, and/or maintenance can cause property damage, injury or death. Read the installation, operating and maintenance instructions thoroughly before installing, servicing or troubleshooting this equipment. Do not use LS-3 Filter to transport hot cooking oil to discard storage.

! NOTICE

If, during the warranty period, the customer uses a part for this FILTROX equipment other than an unmodified new or recycled part purchased directly from FILTROX, or any of its Authorized Service Centers, and/or the part being used is modified from its original configuration, this warranty will be void. Further, FILTROX and its affiliates will not be liable for any claims, damages or expenses incurred by the customer which arise directly or indirectly, in whole or in part, due to the installation of any modified part and/or part received from an unauthorized service center.

If, during this warranty period, the customer uses this equipment for purposes other than to filter cooking oil, i.e. oil discard shuttle or caddy, this warranty will be void.

USER MANUAL

Portable Filter Machine



Description & Construction

The LS-3 is a portable filter machine for filtering hot cooking oil in the restaurant industry. The LS-3 comes in one size – the LS-3-60 with a 60 lb. oil capacity. It has been designed to utilize FILTROX's SuperSorb® Carbon Pad.

The SuperSorb® Carbon Pad is widely acknowledged to be the finest filtration system for cooking oils, giving the operator significant savings in oil usage and the best food quality results. The LS-3 includes features to make the filtration of hot cooking oil as easy and effective as possible. Included are a removable pan for ease of clean up and a sturdy frame for long life and durability.

Frame	Anodized Aluminum Construction
Pan	Welded Anodized Aluminum construction for easy cleaning.
Motor	Rugged 1/3 Horsepower UL and NSF approved motor and gear pump designed for long life.
Electrical Controls	All electrical controls are UL approved and designed to give reliable performance.
Hoses	Half inch diameter, Teflon lined, covered hoses having UL and NSF approvals.
Nozzle	FILTROX's uniquely designed stainless nozzle is designed to reduce splashing while providing a spray that helps in washing the walls of the fryer during filtering.

USER MANUAL

Portable Filter Machine



Product Safety

Safety is of utmost importance when working with heated cooking oils. Throughout this manual you will see the word WARNING which means there is potential danger of equipment damage or personal injury.

Read all instructions thoroughly before installing or operating this equipment.

Inspection and Setup

1. Your LS-3 will arrive in a package carton via ground transportation.
2. Before removing the LS-3 from the carton, inspect the packaging for damage. If damage is seen, please contact the delivering carrier.
3. After inspecting, remove the LS-3 from the carton. You will find that the filter is already completely assembled. Simply hook up the hoses and plug in the electrical cord (not included).
4. Check to make sure the following items are included in the crate :
 - Return hose assembly
 - Support Screen
 - Hold Down Bar
 - Carton of 10-day supply SuperSorb® Carbon Pads
 - 3" pad scraper
 - Monthly Frying Oil Log (Wall Chart)
5. You are now ready to filter. **WARNING: Always follow the operating instructions in this manual when operating the filter.**

WARNING : This ground is to protect the operator from electrical shock in the event of an equipment malfunction. **DO NOT remove or tamper with the ground feature!**

USER MANUAL

Portable Filter Machine



Operating Instructions

The LS-3 has been designed to operate very simply. It is designed as a one-way filter having a simple on/off switch to engage the motor. The quick-disconnect fitting allows for only one-way hook up of hose.

1. Put a SuperSorb® Carbon Pad (bumpy side up) on top of the support screen located in the sump area. Place the hold down bar over the Carbon Pad. Place crumb basket over the Carbon Pad attached to the support pegs and front pan area.

WARNING: Always wear splash goggles or face shield, protective gloves, and appropriate protective safety wear. (See Accessory Section of this manual).

2. Check fryer vat capacity and oil volume to ensure cooking oil does not overflow the pan.

WARNING: The LS-3-60 can hold 60 lbs of cooking oil. Do Not try to filter a fryer with a larger capacity than the LS-3 pan capacity.

3. Attach the drain extension of the fryer to the fryer drain.

WARNING: The end of the drain as well as other parts of the fryer and filter may be hot! Use protective gloves.

4. Roll the LS-3 to the fryer; making sure the fryer drain extension drains into the pan.

WARNING: Always position the filter so that the filter pan is in the proper position beneath the drain. This will prevent heated cooking oil from splashing on the floor. Plug in the LS-3 electrical cord.

5. **Turn off the fryer.** Open the fryer drain valve slowly, draining the cooking oil from the fryer into the filter pan.

6. Make sure the return hose is hooked up and the nozzle is placed into the fryer. Push the on/off switch to "on" position.

7. As the cooking oil is filtered through the SuperSorb® Carbon Pad and returned to the fryer, use the nozzle with returning oil to wash down the sides of the fryer.

USER MANUAL

Portable Filter Machine



8. Once the sides of the fryer are washed down and the bottom of the fryer is clean of all food debris, close the fryer drain valve. Pump all remaining oil from the LS-3 filter back into the fryer. Push the on/off switch to the off position.

WARNING: Never attempt to remove or disconnect hoses when the filter motor is operating.

9. Filter cycle is now complete. Move to the next fryer vat and repeat the process – Steps 2 – 8.
10. When finished with filtering the final fryer vat, continue to pump a small amount of air through the pump/motor assembly to ensure cooking oil is not left in the hoses or pump.

11. Cleaning (**CAUTION: Wait for Filter Machine to cool before cleaning!**) :

- Unplug the main power cord
- Discard used CarbonPad into trash bin
- Disconnect the return hose from upper quick-disconnect ring
- Prior to storing hose drain excess cooking oil from hose by holding nozzle of filter hose over fryer and lifting opposite end of return hose
- Clean hold down bar, support screen, and entire inside of the pan. Wipe dry.

CAUTION: During cleaning DO NOT pump water with the filter pump.

USER MANUAL

Portable Filter Machine



Frying Oil Maintenance

Cooking

1. Cooking temperature not to exceed 360 °F/185 °C. Preferably less than 350 °F/175 °C.
2. Never turn fryer temperature up, before or during a busy period.
3. Turn fryers down or off when not in use. Cover fryers not in use.
4. Never load baskets over a fryer. Never salt food over a fryer.
5. Cook similar foods in the same fryer and separate food types if possible.
6. Skim the fryers often.
7. Add make-up oil often. Do not allow the fryer to be under-filled. Do not over-fill fryers.
8. Never cascade, or downstream oil. Never add old cooking oil to new cooking oil.

Filtering

1. Filter each and every day. (Each day of filtering missed, cuts 1 to 2 days of oil life.)
2. Use a new SuperSorb® Carbon Pad each day.
3. It is preferable to filter at the close of business, or after peak periods.
4. Ensure that no water is in the filter pan before inserting a SuperSorb® Carbon Pad.
5. Turn fryer off, however, filter while cooking oil is still hot (not less than 280 °F).
6. If there are multiple fryers being used, filter the newest cooking oil first, oldest cooking oil last.
7. After draining cooking oil into the filter, wait 2-3 minutes before turning on the pump. Use this time to clean the fryer. Use the LS-3 return hose to rinse debris from the fryer.
8. After rinsing the fryer check to make sure fry pot is clean of all debris. Then close the drain valve and refill fryer.
9. After filtering, allow filter to cool, then clean the filter pan, but never use soap. Avoid bending or kinking the hoses. Dry completely before setting up with a new SuperSorb® Carbon Pad.

Discarding

1. Discard only on the basis of a quality standard. Food quality is the best quality index, but test kits that have been evaluated against food quality may be used.
2. If there are multiple fryers being used, discard only the fry pot that misses the quality mark.
3. Discard cooking oil on a quality standard, not operational ease or by the day of the week.
4. Have a manager or a trained person make the discard decision.

USER MANUAL

Portable Filter Machine



Equipment Specifications

Dimensions for LS-3-60

Weight	64 Lbs.
Overall Dimensions	16.75" wide × 23.75" deep × 27.25" high
Pan Height	11.75"
Total Pan Capacity	1.63 cubic feet or 12.1 gallons
Oil Capacity	60 Lbs. of oil or 7.7 gallons
Pump/Motor	Viking SG-0540 Hot Oil Hub Mount Pump, Capacity: 4.6 GPM at 1750 RPM, 1/3 HP, Capacitor Start, Rotary Gear, Positive Displacement Pump, 115 Volt, 6.2 Amperes, 60-Cycle Motor
Electrical Plug	Standard 3 wire, 15 amp, with NEMA 5-15 plug 0.090" (2.3 mm)
Material	Anodized Aluminum

USER MANUAL

Portable Filter Machine

Dimensions and Detail Drawing

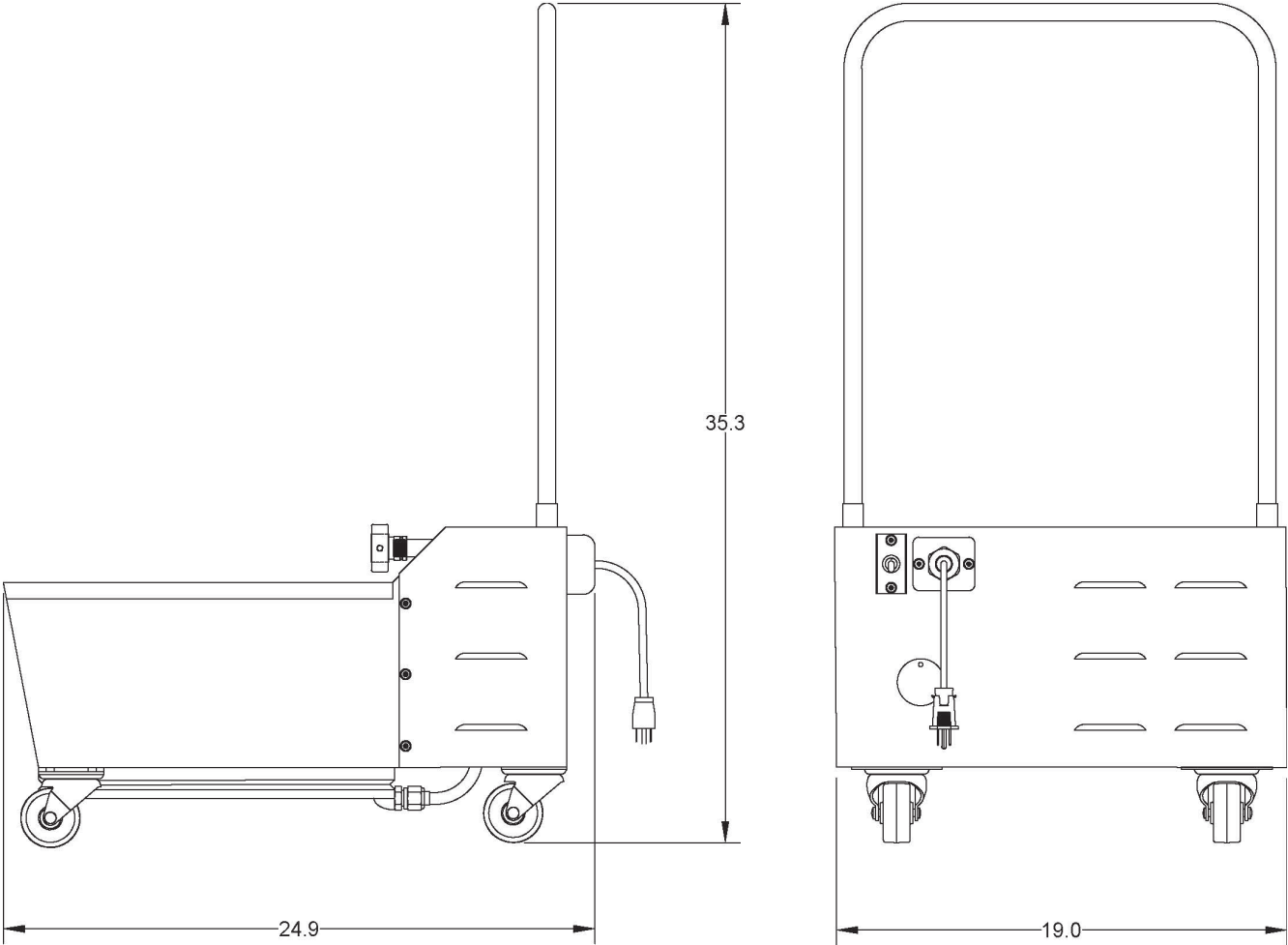

USER MANUAL

Portable Filter Machine



Troubleshooting

PROBLEM	POSSIBLE CAUSE	SOLUTION
Unit will not turn on	<p>A) Power cord is not plugged in</p> <p>B) Power Breaker is tripped</p> <p>C) Motor is overloaded</p> <p>D) Machine plug and extension cord showing exposed wires</p>	<p>A) Check both filter connection and power outlet</p> <p>B) Check to ensure the power outlet breaker in your building is on and hasn't been tripped</p> <p>C) Let motor cool down. Slide open the reset button cover on the side of the LS-2 pump/ motor box. Press reset button. Retry the power switch.</p> <p>D) Replace immediately</p> <p>Warning: make sure the power switch is in the „off“ position before pressing the reset button.</p>
Motor runs but will not pump	A) Hose or pump is blocked	A) Disconnect both hose connections. Turn motor on. Vacuum suction should be felt by placing a finger over the suction intake connection. Check for crimped hose or blockage.
Hoses leak at the connections	A) Loose connections	A) Check to ensure all hose connections are tightened and properly attached and locked. Replace quick disconnects.
Oil filters slowly	A) Check for clogged hoses	Rinse with hot water. Always hang hoses upright for storage to allow oil to drain when not in use.

For additional information, please contact your nearest Authorized Service Agency.

USER MANUAL

Portable Filter Machine



Suggested Frying Oil Protection Apparel

- 400 degree heat protection gloves
- Long apron
- Face shield
- Shin guards



USER MANUAL

Portable Filter Machine



Professional Restaurant Equipment | Original Equipment Warranty

FILTRIX warrants its new product(s) to be free from defects in material and workmanship for a period of the lesser of: (i) one (1) year from date of original installation, or (ii) twelve (12) months from the date of shipment from the factory, provided that proof of installation date is supplied to FILTRIX prior to work being performed.

This Warranty shall be subject to the following conditions and limitations:

1. This warranty is limited to an original commercial user ("OCU") purchasing new Professional Restaurant Equipment ("Equipment") for use with FILTRIX filter media.
2. FILTRIX's obligation under this warranty is limited to repair or replacement of the defective Equipment (or any part of such Equipment) and the labor for such repair or replacement. FILTRIX shall not be liable for any defect unless it has received written notice of such defect within 30 days of the date that the OCU learns of such defective equipment.
3. FILTRIX's warranty obligation as to labor costs is limited to the normal labor charges incurred for such repair or replacement for work done at an authorized FILTRIX service agency. Additionally, for warranty work performed within ninety days after the Equipment is installed, FILTRIX shall be responsible for the normal labor charges for such work provided that it is performed within fifty (50) miles from an office of an authorized FILTRIX agency and performed by an authorized FILTRIX agency. OCR is solely responsible for any labor charges for such work on Equipment that is installed outside the continental United States.
4. FILTRIX shall have no obligation as to any Equipment which have been misapplied, abused, used in a manner other than its intended and normal service, subjected to harsh or improper chemical action or poor water quality, or which has had unauthorized modifications or serviced by unauthorized service personnel, damaged by flood, fire or acts of God or other causes, or which has the serial number removed or altered.
5. Adjustments such as calibrations, leveling, tightening of fasteners or utility connections normally associated with original installation, are the responsibility of the dealer or installer and not that of FILTRIX.
6. FILTRIX shall have no liability for the cost of part(s), labor or travel time to replace fuses or to reset circuit breakers resulting in whole or part from the Equipment or its operation. These costs are the responsibility of the OCU.
7. FILTRIX shall have no obligation as to any Equipment damage or failure relating to or resulting from its use for any purpose other than as a filter machine used to filter edible cooking oils and fats using FILTRIX filtering media. The FILTRIX LS-3 filtration machine is not designed for use as an oil caddy or discard device. It is not recommended that the FILTRIX LS-3 be used in this manner. Damage to the unit and/or personal injury could occur.
8. Certain parts of the Equipment have different warranty periods, which are set forth below:
 - a) High temperature pick-up and return hoses – ninety (90) days from date of installation.
9. OCU's exclusive remedy on a claim of any kind relating to the Equipment whether in contract or in tort or under any other legal theory, and whether arising out of warranties, representations, instructions, installations or defects from any cause shall be limited to repair or replacement of the defective Equipment.
10. In no event shall FILTRIX be liable, whether in contract or in tort, or under any other legal theory, for loss of use, revenue or profit, or for incidental, indirect, or special or consequential damages or for any other loss or claim arising from or relating to the Equipment.
11. This warranty is exclusive and in lieu of all of other warranties, express or implied or statutory, including but not limited to, implied warranties of merchantability or fitness for a particular purpose or usage of trade, and constitutes the only warranty of FILTRIX with respect to the Equipment.
12. Any claims or disputes arising out of or relating to the Equipment or this Document shall be governed by and construed in accordance with the laws of the State of Delaware, without regard to its conflict of laws principles.

The parties agree that any such claims or disputes shall be brought exclusively in the state or federal courts located within the State of Delaware, and the parties hereby expressly consent to the personal and subject matter jurisdiction of such courts. .

It is the policy of FILTRIX that its products are subject to continual improvement. The Company reserves the right to alter the design of any of its products without prior notification. In such circumstances the Equipment described above may differ in certain respects from the one supplied. FILTRIX assumes no responsibility to update any delivered or in-service Equipment and, furthermore, FILTRIX shall not have any obligation to modify the product or Equipment instructions or this warranty regarding Equipment already shipped or installed.

USER MANUAL

Portable Filter Machine



Warranty Registration

Warranty Registration for FILTROX LS-3 Series Portable Filter

Model Number :
Serial Number
Store Name :
Store Number :
Address :
City :
State :
Zip :
Telephone. :
Date of Purchase :
Dealer or Rep Purchased From :
Dealer Invoice Number :

Please complete the Warranty Registration and return to:

FILTROX North America, Inc.

22 Trust Lane, Suite 5

Brevard, NC 28712

email: info@filtroxnorthamerica.com

SERVICE MANUAL

Portable Filter Machine



Anodized Aluminum Filter Machine Models:
LS-3-60

SERVICE MANUAL

Portable Filter Machine



Table of Contents | Service Manual

FILTROX is a leading manufacturer of premium quality filter equipment. We are proud of our reputation for quality and our commitment to customer satisfaction.

We have set high standards for ourselves along with our network of independent Parts Distributors and Service Agencies. As an Authorized Parts Distributor or Authorized Service Agency we are counting on you to represent our company in a professional manner. We are here to help support you should you need help.

Our Technical Support Center is staffed by experienced technicians eager to help you. Our Technical assistance and Service parts ordering number is (800) 473-4526 x150 and we are available 8:00 am (CST) to 5:00 pm (CST).

This Service Manual, and the User Manual that precedes it, are designed to provide you with the information needed to properly diagnose and repair the LS-3 Portable Cooking Oil Filter. We are proud of this appliance as we believe it offers a terrific filtering experience. Your understanding of the design and function of this appliance is an important part of the repair process. If you need help, please contact us.



SERVICE MANUAL

Portable Filter Machine



Table of Contents | User Manual

Note to Service Technicians	Page 20
Wiring diagram for Viking Pump	Page 21
Installation view for Viking Pump	Page 22
Parts Listing	Page 23-25

SERVICE MANUAL

Portable Filter Machine



Note to Service Technicians

This manual is not a stand alone document. You must read and become familiar with the content of the User Manual and Instruction sheet (LS-3 Portable Filter Procedures) to effectively troubleshoot and repair this equipment.

Reported Troubles signales

1. The pump operates, but does not pump oil. This is often diagnosed as a bad pump but usually is caused by a block or crimp in the pick-up hose. To test the pump, remove the pick-up hose quick disconnect and put your finger on the pump intake. If it pulls a good vacuum, the pump is good. The pick-up hose may be kinked such that it permits a small amount of flow (when you test the hose, water flows through it) but not enough to operate effectively.
2. Water should never be run through the pump. Water will cause corrosion within 24 hours. The corrosion will lock up the pump. If water is accidentally pumped, immediately flush the pump with hot cooking oil.
3. Pumps that do not rotate can often be adjusted to correct the problem instead of replacing the pump.
4. A quick disconnect that won't connect is usually caused by particles inside the quick disconnect. Using the filter system without a filter pad causes the particles to circulate and become lodged in the quick disconnects and the pump.

SERVICE MANUAL

Portable Filter Machine



Wiring diagram for Viking Pump

LABEL 3 H.O

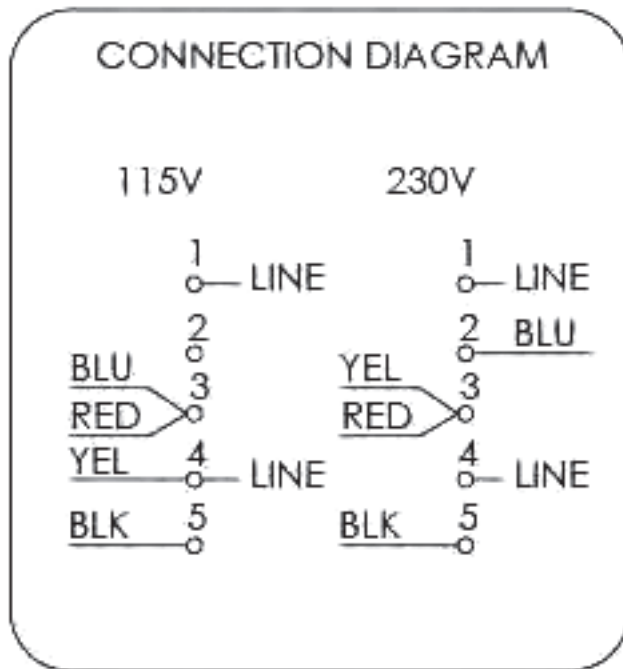

SERVICE MANUAL

Portable Filter Machine

Installation view for Viking pump upside down with adapter plug

MOTOR: 1/3 HP, 1425/1725 RPM,
56YZ FRAME,
50/60/115/230V, ODP,
MANUAL THERMAL OVERLOAD,
P/N 2-547-21H-999-00

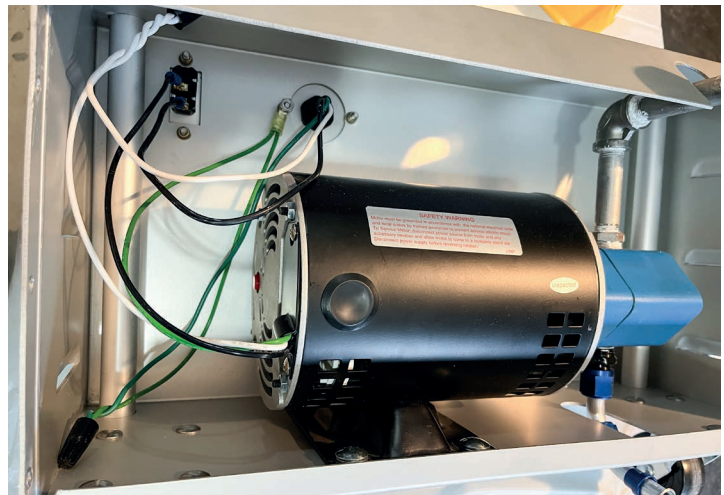
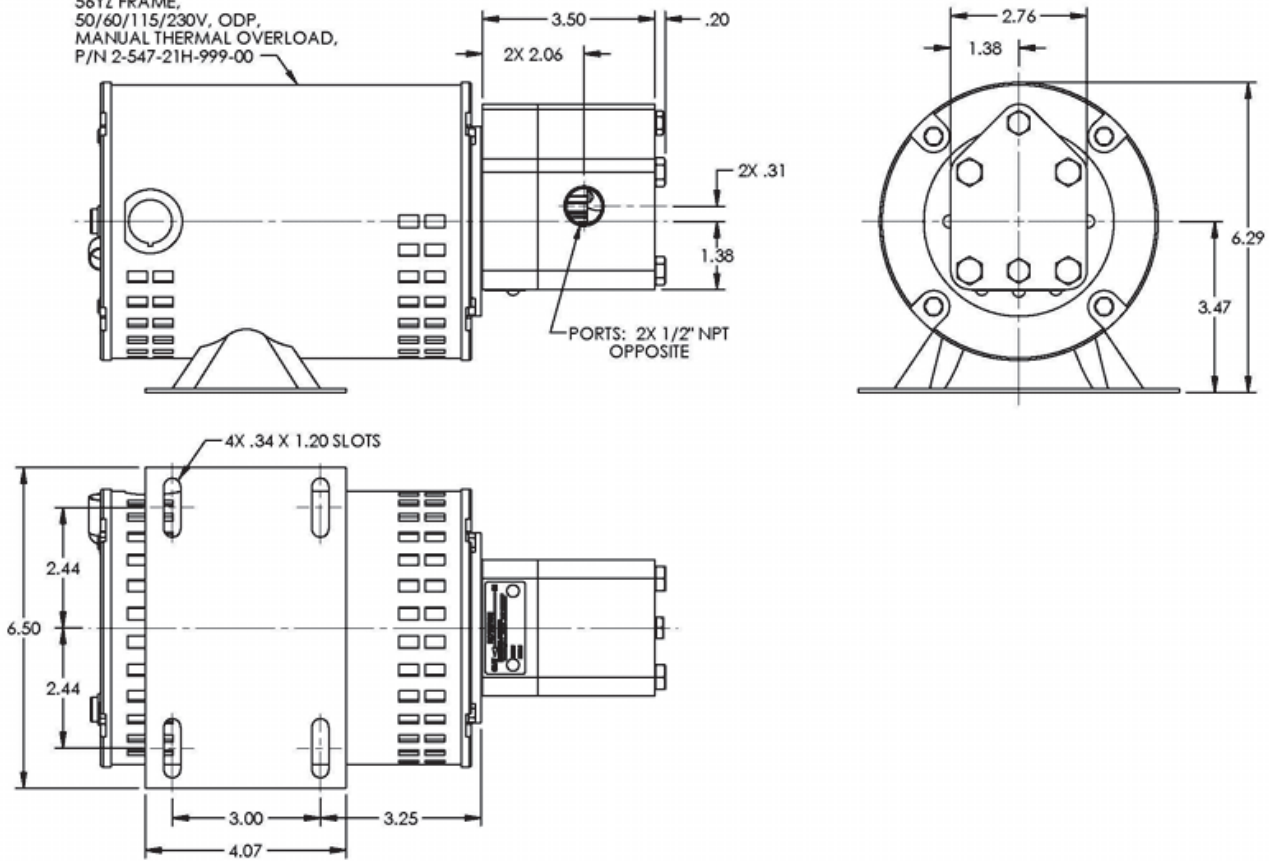

SERVICE MANUAL

Portable Filter Machine



Parts Listing



Item	Part Number	Description
1	848-04	2.5" Caster (Swivel with Brake), Aluminum Units
2	69002857	LS-3 60 Bucket
3	69002329	LS-3 60 Grate Screen
4	69002330	Hold down bar (shown with F-40 SuperSorb Carbon Pad, bumpy side up)
5	1012 1012A	Quick Disconnect Fitting, Snaptite, 3/8" Female, NPT Safety Donut for Part #1012

SERVICE MANUAL

Portable Filter Machine

Parts Listing

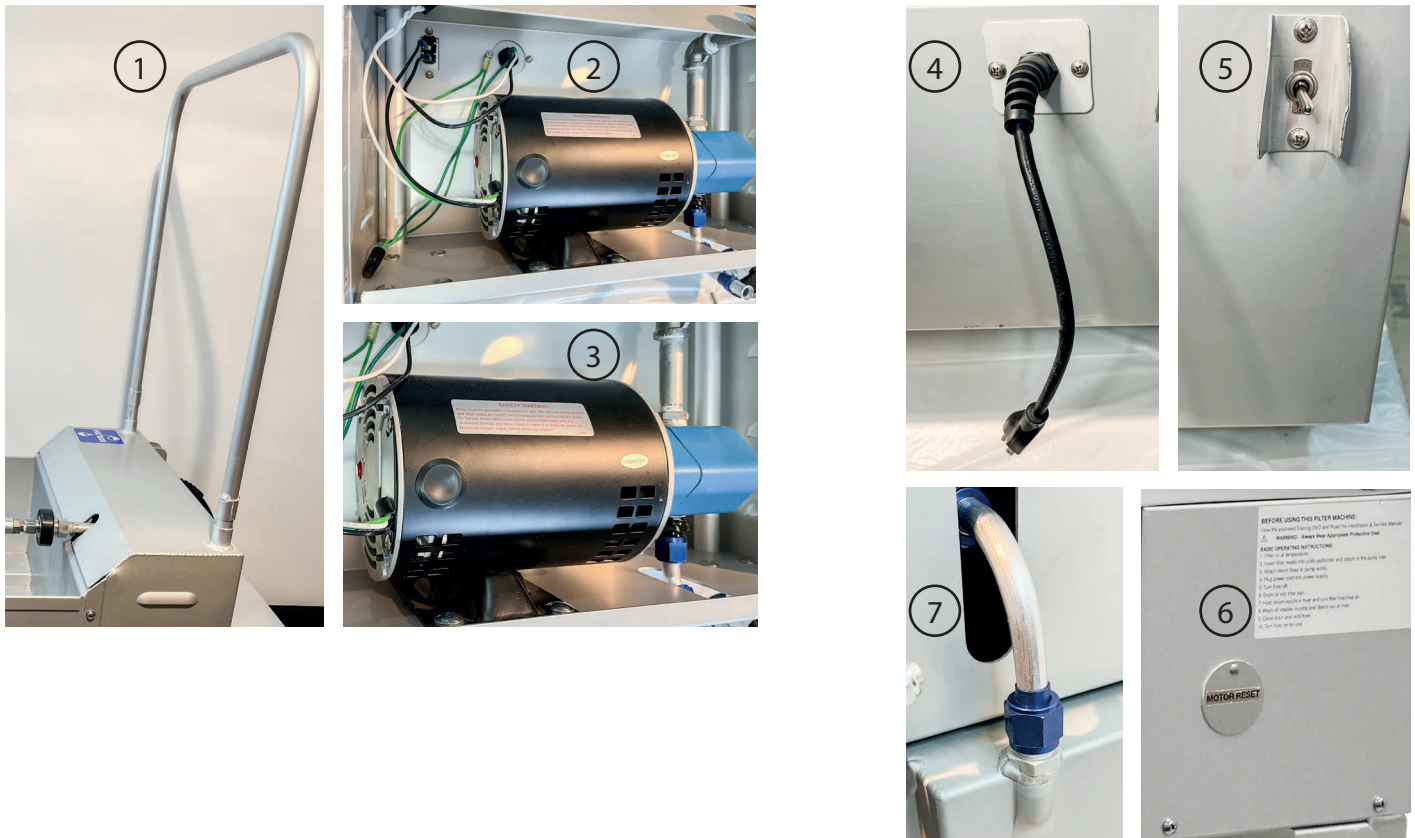

Item	Part Number	Description
1	69002855	Removable Handle
2	69002328	Motor Housing (pictured with Viking Motor Pump)
3	4GPM-SG0510-21H	Viking Motor Pump Assembly
4	69002331	Pig Tail Plug Kit
5	847-01	On-Off Switch
6	847-09	Reset Button Cover
7	69002326	Rigid Pipe Assembly

SERVICE MANUAL

Portable Filter Machine



Parts Listing

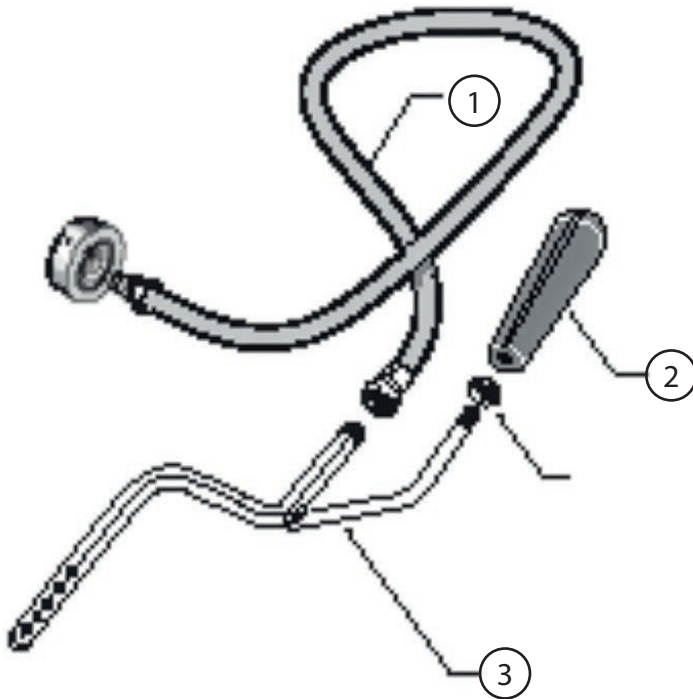

Item	Part Number	Description
1	855A	62" Return Hose
2	856XW	Nozzle White Poly Hand
3	856 AL	Hand Nozzle Shower Spray (1 Bend)
4	1015	Male Quick Disconnect Fitting
5	69002857	Optional Bucket Cover (not pictured)
6	69002856	Optional Crumb Basket (not pictured)